



DEFENDER SERIES® SPILL CONTAINERS

Defender Series® five gallon spill containers combine years of knowledge and experience in forecourts across the globe to represent the best defense in spill containment. Proactively protecting a site from the dangers of fugitive emissions during fuel delivery can save station owners both time and money by avoiding remediation due to fuel leakage. Available in both grade level and below grade level models to meet the needs of your application and preference, the complete lineup of Defender Series® spill containers provides a durable, easy-to-install, and simple-to-maintain and service spill containment solution for any environment and any application.

HIGHLIGHTS

- Available in both grade level and below grade level models to meet the needs of your application and preference.
- Double wall protection complete with integrated visual interstitial integrity monitor or electronic sensor monitoring options for the secondary containment space (single wall grade level option available).
- Visual interstitial monitor facilitates efficient monthly inspections of the integrity of the secondary containment space during walk-through inspections.
- Electronic sensor monitor provides active integrity monitoring of the secondary containment space, providing immediate alarm of liquid when paired with an automatic tank gauge.
- Drop tube adapter ensures a vapor tight seal and easy in and out of drop tube / overfill prevention valve during installation or maintenance.
- Drain valve option, designed to meet CARB leak rate requirements, drains any spilled fuel into the tank.
- Grade level spill containers feature a rugged concrete ring, sturdy snow plow ring, and cast iron lid to deflect forecourt traffic. Their integrated liquid dam and gasketed lid prevent water entry. The container is housed inside a ribbed roto-molded PE gravel guard.
- Below grade spill containers feature a flush fiberglass composite manway lid allowing forecourt traffic to pass cleanly over its top. The gasketed lock-down cover seals water out. The container is protected by a solid steel manway skirt.
- Grade level spill containers offer variable installation height adjustment making it easy to ensure proper installation.
- Below grade spill containers install easily, and cleanly into the included 18" manway for simple installation.
- Easily upgrade from single to double wall without breaking concrete.

SPECIFICATIONS

Components

- Primary containment
- Secondary containment
- 1 Adapter cap
- 2 Swivel adapter
- 3 Nipple
- 4 Drop tube adapter
- 5 Drain
- 6 Visual monitor
- 7 Electronic sensor monitor
- 8 Lock down lid
- 9 18" manway
- 10 Fiberglass manyway lid
- 11 Gravel guard
- 12 Cast iron gasketed lid

Below Grade

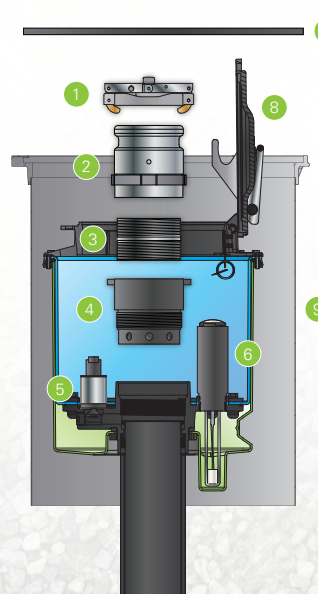

Grade Level

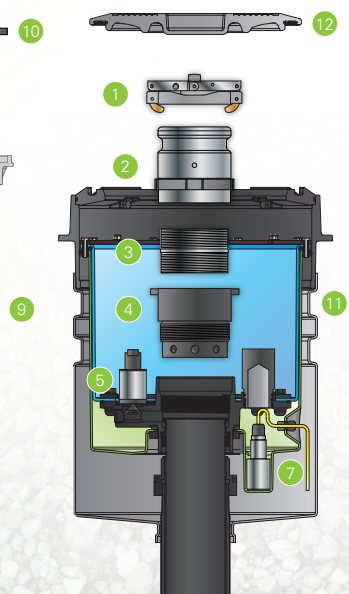

SPECIFICATIONS CONTINUED

Grade Level Spill Container Dimensions

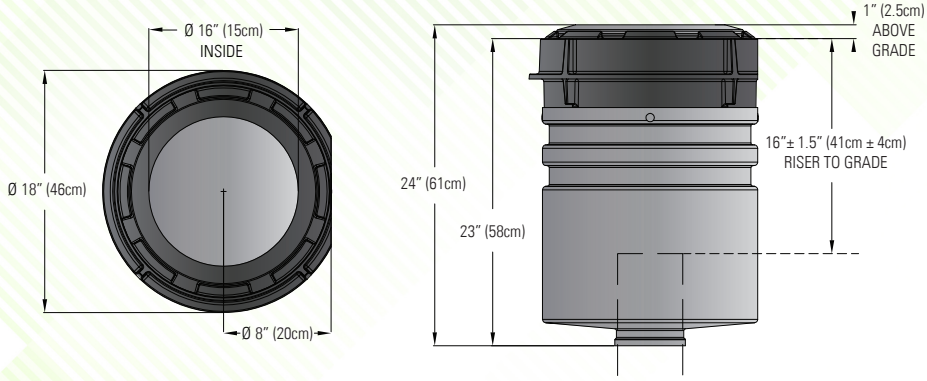

Below Grade Spill Container Dimensions

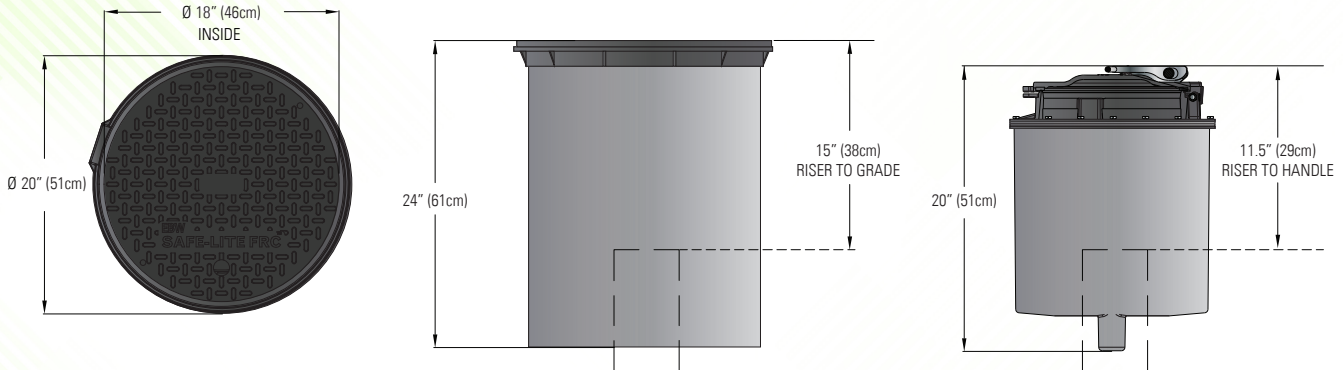

Configurations

Below Grade
Double Wall
Visual Monitor

Below Grade
Double Wall
Electronic Monitor

Grade Level
Single Wall

Grade Level
Double Wall
Visual Monitor

Grade Level
Double Wall
Electronic Monitor

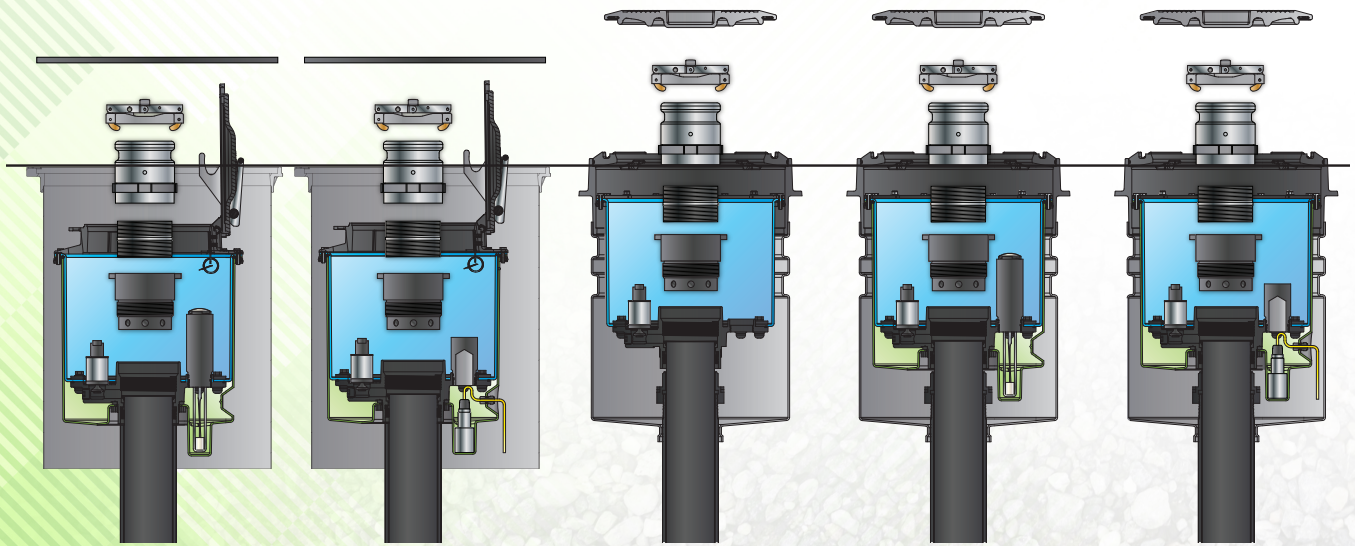

SPECIFICATIONS CONTINUED

Approvals/Certifications

- ULC Listed (grade level CI-GKT versions only).
- CARB approved (grade level only).
- Exceeds H20 and HS20 load standards (maximum axle load requiring support for the 32,000 or 16,000 pounds for each set of dual tire wheels).

ORDERING INFORMATION

Ordering Guide

Complete spill container part numbers have a specific order and are created using the following guidelines:

705 XXXY A B C

XXX = Containment Options

- 545 = Grade level single wall
- 555 = Grade level double wall
- 556 = Below grade double wall

Y = Interstitial Monitoring Options

- 0 = No sensor
- 1 = Visual monitor (float gauge)
- 2 = Electronic sensor monitor

A = Base Thread Options

- 0 = NPSM
- 1 = NPT
- 2 = BSPT

B = Drain Options

- 1 = With drain
- 2 = Without drain

C = Lid/Cover

- BLK = Black fiberglass 18" manway cover (below grade only)
- CI-GKT = Black epoxy-coated cast iron gasketed lid (grade level only)
- CI-GRN = Green epoxy-coated cast iron gasketed lid (grade level only)
- CI-ORG = Orange epoxy-coated cast iron gasketed lid (grade level only)
- CI-RED = Red epoxy-coated cast iron gasketed lid (grade level only)
- CI-WHT = White epoxy-coated cast iron gasketed lid (grade level only)
- CI-YEL = Yellow epoxy-coated cast iron gasketed lid (grade level only)

Example: **705555111CI-GKT** = Defender Series® grade level double wall spill container with visual monitor, with NPT base thread, with drain and with black cast iron gasketed lid.

Example: **705556211BLK** = Defender Series® below grade double wall spill container with electronic sensor monitor, with NPT base thread, with drain and with black fiberglass manway cover (manway included).

Defender Series® Spill Containers Common Configurations

Model	Description
705545001CI-GKT	Defender Series® grade level, single wall, NPSM thread, with drain, with black epoxy-coated cast iron gasketed lid
705545002CI-GKT	Defender Series® grade level, single wall, NPSM thread, without drain, with black epoxy-coated cast iron gasketed lid
705545011CI-GKT	Defender Series® grade level, single wall, NPT thread, with drain, with black epoxy-coated cast iron gasketed lid
705545012CI-GKT	Defender Series® grade level, single wall, NPT thread, without drain, with black epoxy-coated cast iron gasketed lid
705545021CI-GKT	Defender Series® grade level, single wall, BSPT thread, with drain, with black epoxy-coated cast iron gasketed lid
705545022CI-GKT	Defender Series® grade level, single wall, BSPT thread, without drain, with black epoxy-coated cast iron gasketed lid
705555101CI-GKT	Defender Series® grade level, double wall, NPSM thread, with drain, with visual monitor, with black epoxy-coated cast iron gasketed lid
705555102CI-GKT	Defender Series® grade level, double wall, NPSM thread, without drain, with visual monitor, with black epoxy-coated cast iron gasketed lid
705555111CI-GKT	Defender Series® grade level, double wall, NPT thread, with drain, with visual monitor, with black epoxy-coated cast iron gasketed lid
705555112CI-GKT	Defender Series® grade level, double wall, NPT thread, without drain, with visual monitor, with black epoxy-coated cast iron gasketed lid
705555211CI-GKT	Defender Series® grade level, double wall, NPT thread, with drain, with electronic sensor monitor, with black epoxy-coated cast iron gasketed lid
705555212CI-GKT	Defender Series® grade level, NPT thread, without drain, with electronic sensor monitor, with black epoxy-coated cast iron gasketed lid
705556111BLK	Defender Series® below grade, double wall, NPT thread, with drain, with visual monitor, with black fiberglass manway cover (18" manway included)
705556112BLK	Defender Series® below grade, double wall, NPT thread, no drain, with visual monitor, with black fiberglass manway cover (18" manway included)
705556211BLK	Defender Series® below grade, double wall, NPT thread, with drain, with electronic sensor monitor, with black fiberglass manway cover (18" manway included)
705556212BLK	Defender Series® below grade, double wall, NPT thread, no drain, with electronic sensor monitor, with black fiberglass manway cover (18" manway included)
705559901*	Defender Series® grade level cutaway display, double wall, with drain, with visual monitor

*For display and demonstration purposes only. Six to eight week lead time.

Defender Series® Spill Container Installation Tools

Model	Description
T-7001	T-handle wrench
T-7106	Double-ended installation tool
T-7107	Double wall vacuum test kit (for double wall models only)

ORDERING INFORMATION CONTINUED

Grade Level Single Wall Replacement Parts

#	Model	Description
1	70544011	Cover, cast iron w/gasket (black)
2	70551911	Cover gasket
3	70553001	Plow ring assembly
4	602009007	Plow ring gasket
5	70541202	Fill riser, cap, and adapter kit
6	77720102	Top seal fill cap
7	SWF-100-SS	Fill swivel adapter
8	70521307	4" x 2.88" close nipple
9	70541302	Vapor riser, cap, and adapter kit
10	30430103	Top seal vapor cap
11	SWV-101-SS	Vapor swivel adapter
12	70550901EC	DT riser clamp assembly
13	1103939	DT riser gasket
14	70533729	Pull-to-push drain valve kit
15	70550311	Spill container seal ring gasket
16	602256001	Tank riser gasket
17	705545001SP	Spill container, NPSM, with drain
	705545002SP	Spill container, NPSM, no drain
	705545011SP	Spill container, NPT, with drain
	705545012SP	Spill container, NPT, no drain



Grade Level Double Wall Replacement Parts

#	Model	Description
1	70544011	Cover, cast iron w/gasket (black)
2	70551911	Cover gasket
3	70553001	Plow ring assembly
4	602009007	Plow ring gasket
5	70541202	Fill riser cap and adapter kit
6	77720102	Top seal fill cap
7	SWF-100-SS	Fill swivel adapter
8	70521307	4" x 2.88" close nipple
9	70541302	Vapor riser, cap, and adapter kit
10	30430103	Top seal vapor cap
11	SWV-101-SS	Vapor swivel adapter
12	70550901EC	DT riser clamp assembly
13	1103939	DT riser gasket
14	70533729	Pull-to-push drain valve kit
15	70553301	I ² monitor and inspection port kit
16	TSP-ULS	Electronic leak detection sensor
17	70553302	Sensor inspection port
18	70550311	Spill container seal ring gasket
19	602256001	Tank riser gasket
20	705555101SP	Spill container, I2, NPSM, with drain
	705555102SP	Spill container, I2, NPSM, no drain
	705555111SP	Spill container, I2, NPT, with drain
	705555112SP	Spill container, I2, NPT, no drain
	705555201SP	Spill container, sensor, NPSM, with drain
	705555202SP	Spill container, sensor, NPSM, no drain
	705555211SP	Spill container, sensor, NPT, with drain
	705555212SP	Spill container, sensor, NPT, no drain

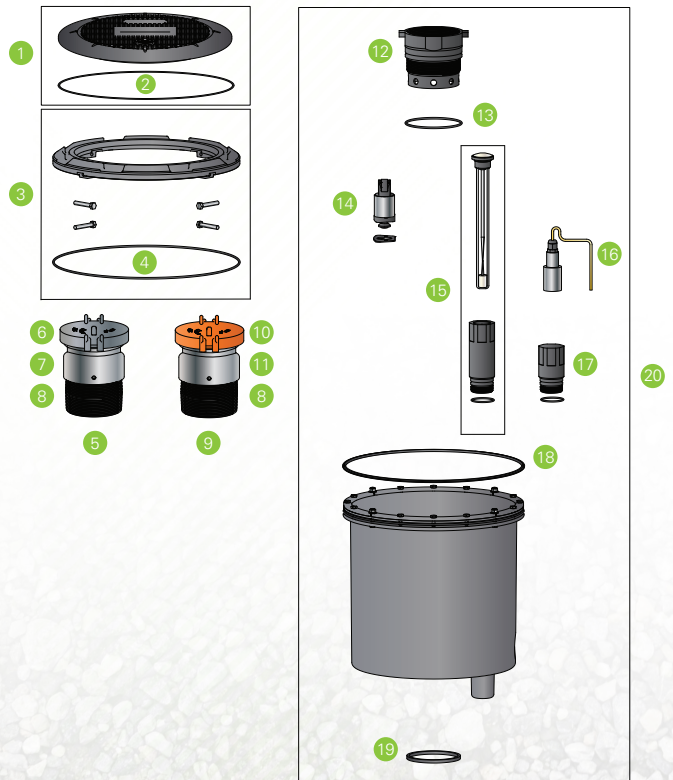

ORDERING INFORMATION CONTINUED

Below Grade Double Wall Replacement Parts

#	Model	Description
1	78130401	Cover, 18" fiberglass (black)
2	705587901	Lock down cover assembly
3	70541202	Fill riser cap and adapter kit
4	77720102	Top seal fill cap
5	SWF-100-SS	Fill swivel adapter
6	70521307	4" x 2.88" close nipple
7	70541302	Vapor riser, cap, and adapter kit
8	30430103	Top seal vapor cap
9	SWV-101-SS	Vapor swivel adapter
10	70550901EC	DT riser clamp assembly
11	1103939	DT riser gasket
12	70533729	Pull-to-push drain valve kit
13	70553301	I ² monitor and inspection port kit
14	TSP-ULS	Electronic leak detection sensor
15	70553302	Sensor inspection port
16	70550311	Spill container seal ring gasket
17	602256001	Tank riser gasket



franklinfueling.com
 3760 Marsh Rd. • Madison, WI 53718, USA
 Tel: +1 608 838 8786 • Fax: +1 608 838 6433
 Tel: USA & Canada +1 800 225 9787 • Tel: UK +44 (0) 1473 243300
 Tel: Mex 001 800 738 7610 • Tel: FR +33 (0) 1 69 21 41 41 • Tel: CH +86 10 8565 4566



© 2017 Franklin Fueling Systems. All Rights Reserved.